

(No Model.)

D. S. CHESEBRO.
TUBE CUTTER.

No. 422,725.

Patented Mar. 4, 1890.

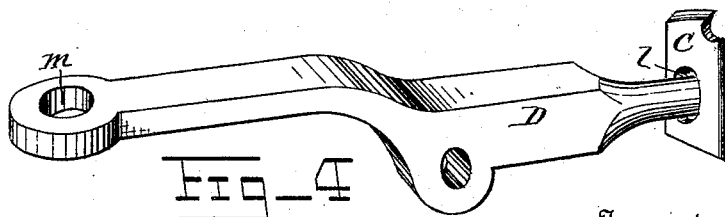
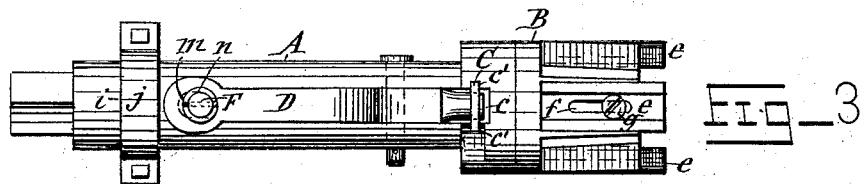
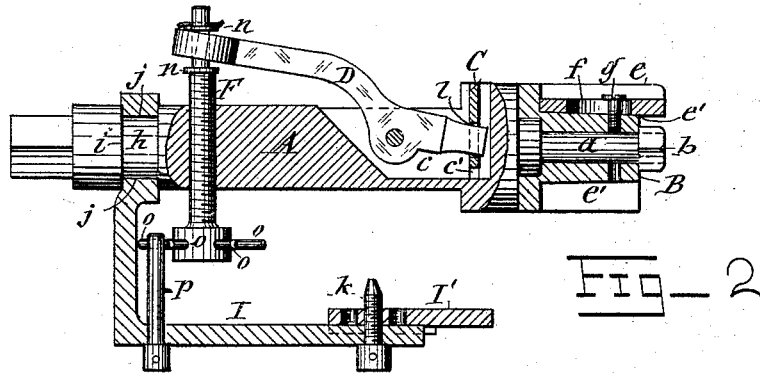
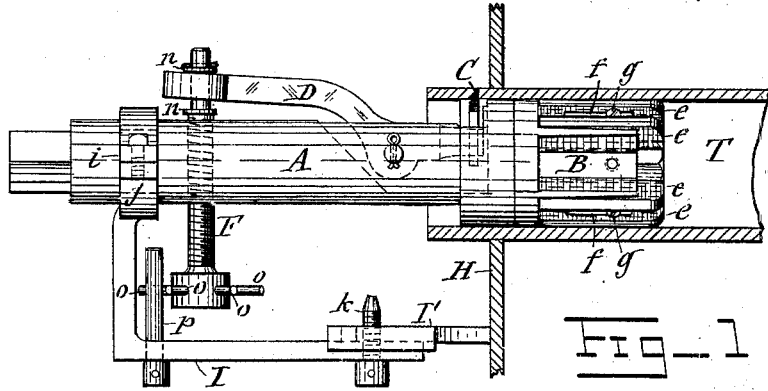

Witnesses

C. L. Bendison
J. J. Looser

Inventor

Henison S. Chesbro

By his Attorneys

Hull, Laass & Hull

UNITED STATES PATENT OFFICE.

DENISON S. CHESEBRO, OF SYRACUSE, NEW YORK.

TUBE-CUTTER.

SPECIFICATION forming part of Letters Patent No. 422,725, dated March 4, 1890.

Application filed August 27, 1888. Serial No. 283,817. (No model.)

To all whom it may concern:

Be it known that I, DENISON S. CHESEBRO, of Syracuse, in the county of Onondaga, in the State of New York, have invented new and useful Improvements in Tube-Cutters, of which the following, taken in connection with the accompanying drawings, is a full, clear, and exact description.

This invention consists in an improved construction and combination of the components of a tube-cutter, whereby the tube can be cut either at the inside or at the outside of the flue-sheet, and which is adapted to operate on tubes of different sizes, and cuts the tube smoothly and without flaring the cut end thereof.

The invention also consists in novel devices for automatically feeding or moving the cutter to its operative position during the operation of the cutter; and the invention furthermore consists in a novel adjustable support for the inner end of the tube-cutter mandrel, and in certain peculiarities of the details of the tube-cutter, as hereinafter fully described, and specifically set forth in the claims.

In the annexed drawings, Figure 1 is a side view of my improved tube-cutter in position for cutting a tube at the outside of the flue-sheet. Fig. 2 is partly a longitudinal section of the tube-cutter and its supports. Fig. 3 is a side view of the same in a plane at right angles to those shown in the previous figure, and Fig. 4 is an enlarged perspective view of the cutter and its adjusting-lever.

A denotes the mandrel, which is at one end supported in the tube T by a holder B, which is adapted to be inserted into the tube, and has one end of the mandrel pivoted to it, and preferably detachably connected by means of a spindle *a*, projecting from the end of the mandrel and longitudinally through the holder B, and having its end screw-threaded and a nut *b* applied thereto to couple the aforesaid parts together.

In order to render said holder adjustable to different-sized tubes, I provide the holder with suitable seats *e' e'* for interchangeable gibs *e e* of different thicknesses, and preferably form said gibs and their seats tapering longitudinally and reversed from each other, and provide the gibs with longitudinal slots

f for the reception of the screws *g*, by which they are secured to the holder B, said slots allowing the gibs to be shifted longitudinally and the aforesaid tapers causing the gibs to project radially from the holder to a greater or less degree.

The outer end of the mandrel A is provided with a journal *h*, and with a shoulder *i* at the outer end of said journal, and is thereby pivotally supported on a bracket I, which is formed with two arms at right angles to each other, and one of said arms rests against the flue-sheet H, and the other arm is provided with a bearing *j* for the journal *h* of the mandrel. The bearing of the shoulder *i* against the side of the journal-bearing *j* prevents the mandrel A from moving longitudinally, and thus maintains the mandrel in its requisite position to cut the tube at the desired point.

To allow the mandrel to be adjusted so as to cut the tube either at the inside or outside of the flue-sheet, I form the bracket I with an extension I', which is connected thereto adjustably toward and from the flue-sheet. The adjustability may be attained either by two or more bolt-holes or a slot for the reception of the bolt *k*, by which the extension I' is attached to the bracket.

The mandrel A is provided with a longitudinal groove *c*, and in the side walls of this groove are rectilinear radial grooves *c' c'*, in which latter is seated movably the cutter-blade C, which is thus guided rectilinearly and at right angles to the axis of the mandrel, and consequently cuts the tube squarely or at right angles to its axis. The cutter-blade being sustained rigidly opposed to the material presented to its cutting-edge during the process of cutting; the tube causes the said blade to act in the same manner as the cutter on a planer or a cutter fixed to a tool-post on a lathe, and therefore cuts the tube without expanding the same. Said expansion is a serious defect in that it prevents the tube from being removed through the flue-hole in the flue-sheet of the boiler, and also ruins the end of the tube, so as to prevent another section of tube being welded onto it when desired.

In the longitudinal groove *c* is pivoted a lever D, on the inner end of which is mounted movably laterally the cutter C in any suitable

ble manner, preferably by the end of the lever passing through an aperture *l* in the cutter, as best seen in Fig. 4 of the drawings, thereby affording to the lever such a holder
 5 on the cutter as to prevent the latter from slipping out and becoming locked on the tube when the cutter has penetrated said tube at one point. The outer end of the lever *D* is formed with an aperture *m*, and through this
 10 projects the smooth end portion of a screw *F*, which works in a screw-threaded perforation extending transversely or diametrically through the mandrel. Said smooth end portion of the screw is provided with collars *n n*
 15 above and below the lever, and is thus swiveled on the lever, so that by turning the screw it is caused to either draw said end of the lever toward the mandrel or push it from the same, according to the direction in which
 20 the screw is turned. Said swiveled connection is also essential to prevent undue protrusion of the cutter, as aforesaid.

The draft of the lever toward the mandrel causes the opposite end of the lever to push
 25 the cutter *C* radially outward from the mandrel, and in this manner the cutter is adjusted or fed to its operative position. In order to accomplish this latter adjustment or feed automatically during the operation of the cutter, I provide the screw *F* with radial arms *o*
 30 *o*, which project therefrom, so as to encounter during the rotation of the mandrel either the bracket *I* or an extra post *p*, attached to said bracket, said encounter causing the screw to
 35 be turned, and thus effect the adjustment of the cutter, as aforesaid.

Having described my invention, what I claim as new, and desire to secure by Letters Patent, is—

40 1. The combination of the mandrel provided with rectilinear radial guides, a lever fulcrumed on the mandrel, and a cutter mounted movably laterally on said lever and seated in the aforesaid guides and sustained
 45 therein rigidly opposed to the material presented to the cutting-edge of the cutter, substantially as set forth.

2. The combination of the mandrel provided with rectilinear radial guides, a lever
 50 fulcrumed on the mandrel, a cutter mounted movably laterally on the inner end of said lever and seated in the aforesaid guides and

sustained therein rigidly opposed to the material presented to the cutting-edge of the cutter, and a feed-screw connected to the
 55 mandrel transversely to the axis thereof and swiveled to the outer end of the aforesaid lever, substantially as described and shown.

3. The combination of the mandrel *A*, provided with the radial grooves *c' c'* and diametrical screw-threaded perforation *d'*, the
 60 cutter *C*, guided in said grooves and provided with the perforation *l*, the lever *D*, fulcrumed on the mandrel and having its inner end extending through the perforation *l* of the cutter and provided at its outer end with the
 65 aperture *m*, and the screw *F*, working in the perforation *d'*, and having its end portion smooth and extending through the aperture *m* and provided with collars *n n* above and
 70 below the lever, substantially as described and shown.

4. The combination of a tube-cutter mandrel supported at one end in the tube; a bracket pivoted to and supporting the opposite
 75 end of the mandrel, a cutter seated radially adjustable in the mandrel, a lever pivoted to the mandrel and supported by one of its ends, the cutter, an adjusting-screw connected to the mandrel and swiveled to the
 80 lever, and arms projecting from the adjusting-screw and adapted to encounter the bracket during the rotation of the mandrel, and thereby turn the adjusting-screw and automatically feed the cutter, substantially
 85 as set forth.

5. In combination with the mandrel, the holder *B*, pivotally connected to said mandrel and formed with seats *e' e'*, tapered longitudinally, the gibs *e e*, tapered reverse from said
 90 seats and provided with longitudinal slots *f*, and screws *g*, inserted in said slots and adjustably fastening the gibs to the seats *e' e'*, substantially as described and shown.

In testimony whereof I have hereunto signed
 95 my name, in the presence of two witnesses, at Syracuse, in the county of Onondaga, in the State of New York, this 25th day of August, 1888.

DENISON S. CHESEBRO. [L. S.]

Witnesses:

C. L. BENDIXON,
 J. J. LAASS.